

Fig 1

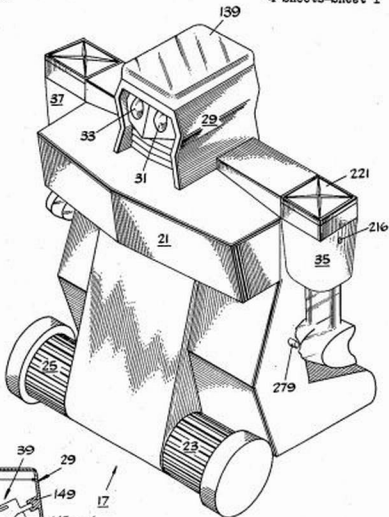
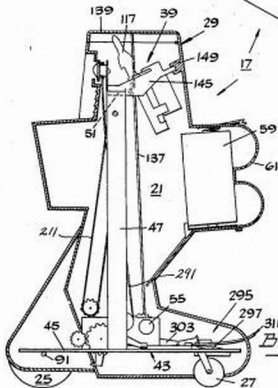
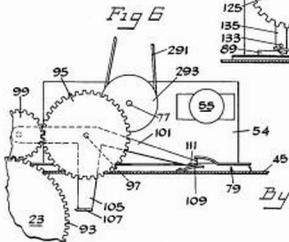
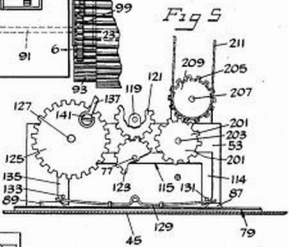
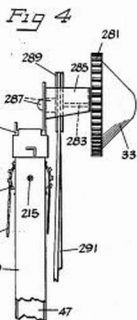
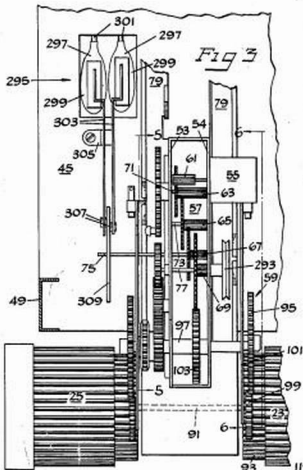

Fig 2



Inventor's
Marvin I. Glass
Leonid Kripak

By *Joans, Anderson, Luedeka & Fitch*
Attys



Inventor's
 Marvin I. Glass
 Leonid Kripak

By *Sonne, Anderson, Luetsch & Fitch*
 Atty's

REMOTELY CONTROLLED ELECTRIC TOY

Filed Oct. 17, 1960

4 Sheets-Sheet 3

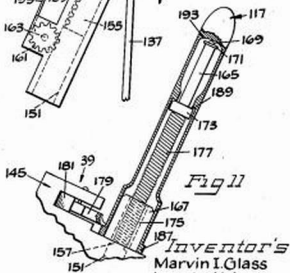
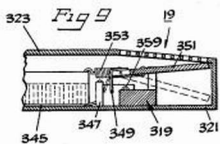
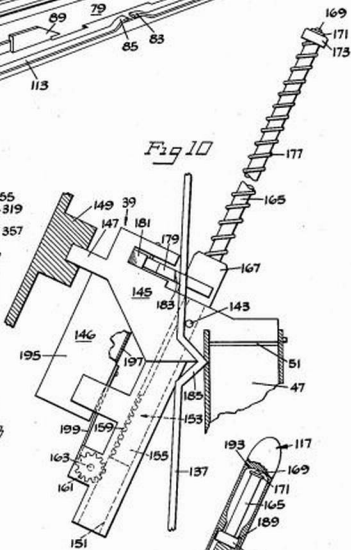
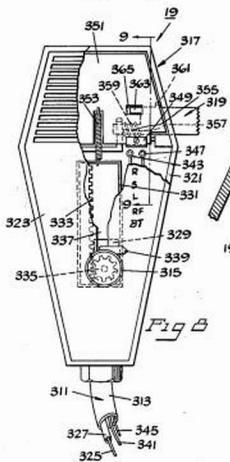
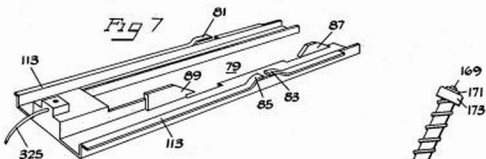

Inventor's
Marvin I. Glass
Leonid Kripak

By *Sperry, Anderson, Lundell & Fitch*
Att'y's

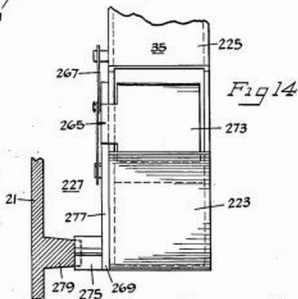
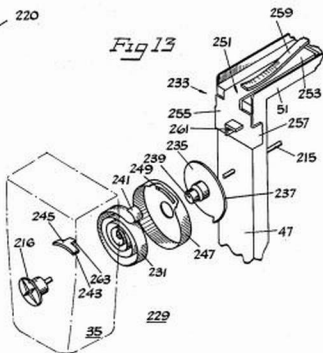
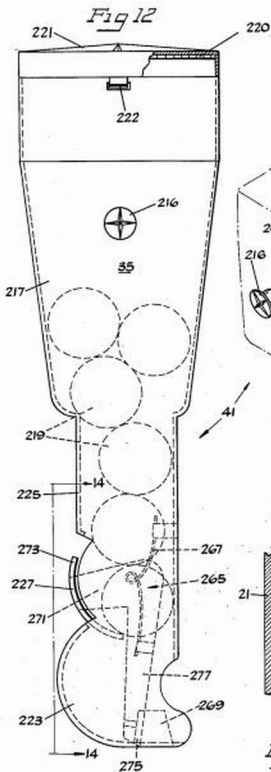

Inventor's
Marvin I. Glass
Leonid Kripak

By *Soane, Anderson, Luskala & Rich*
Atty's

1

3,103,762

REMOTELY CONTROLLED ELECTRIC TOY

Marvin I. Glass, Chicago, and Leonid Kripak, Villa Park, Ill.; said Kripak assignor to said Glass
Filed Oct. 17, 1960, Ser. No. 63,097
17 Claims. (Cl. 46-232)

This invention relates generally to toys which are remote controlled. The invention also relates to self-propelled toys. More particularly, the invention relates to self-propelled toys which are controllable from a remote point and which incorporate one or more fascinating and/or realistic, attention attracting, operational features, such as special auditory and visual effects, variably controllable multi-directional travel, and missile firing features. Still more particularly, the invention relates to toys which are intended to simulate, both in appearance and activity, a mechanical creature or robot.

In this ever-advancing age of science everyone, including children, is subject to ever increasing exposure, by virtue of newspapers, magazines, and television, to the concept of automated activities by mechanisms and devices which are remotely controlled and which may perform certain actions suggestive of human endeavor. As a result, youngsters are becoming more and more interested in, and attracted toward, mechanical creatures. Accordingly, the general object of the invention is the provision of a toy which is suggestive of a mechanical creature or robot and which, when coupled with the far reaching imagination of a child, will provide many long hours of play.

More specific objects of the invention include the provision of a self-propelled toy which includes mechanism operable to drive the toy over any selected path or track, which includes one or more missile firing mechanisms, with or without related means for producing an associated realistic sound effect, and/or which is remotely controllable, at least in part, by sound command.

Other objects of the invention include the provision of various operating components and devices which, in this disclosure, are described in functional and structural combination in a "robot" toy.

Other objects and advantages of the invention will become apparent by reference to the following description and the accompanying drawings of one embodiment of the invention in which:

FIGURE 1 is a perspective view of a toy which resembles a robot and which embodies various of the features of the invention;

FIGURE 2 is an elevational view, partially in section, showing the general layout of the interior mechanism within the robot;

FIGURE 3 is an enlarged, partial plan view of a portion of the operating mechanism of the robot;

FIGURE 4 is a fragmentary side view of a portion of the operating mechanism within the robot;

FIGURE 5 is a fragmentary view taken generally along line 5-5 of FIGURE 3;

FIGURE 6 is a fragmentary view taken generally along line 6-6 of FIGURE 3;

FIGURE 7 is a perspective view of the slide by means of which various of the operating components are connectable to the motor;

FIGURE 8 is a plan view, partially broken away, of the remote unit for controlling the robot;

FIGURE 9 is a sectional view taken generally along line 9-9 of FIGURE 8;

FIGURE 10 is an enlarged fragmentary view, partially broken away and sectioned, showing the rocket firing device incorporated in the robot;

FIGURE 11 is a partially broken away and sectioned,

2

fragmentary view illustrating engagement of the rocket in firing position on the firing device;

FIGURE 12 is an enlarged side view, partially broken away and sectioned, one of the arms of the robot;

FIGURE 13 is an exploded, diagrammatic perspective view of a portion of the mechanism for rotating the arms of the robot; and

FIGURE 14 is a fragmentary view, partially in section, taken along line 14-14 of FIGURE 12.

The toy illustrated in the drawings is an animated wheeled figure which is selectively controllable from a remote point so as to propel itself over any desired path and to discharge one or more types of projectiles. In addition, the toy continually produces a vitality-simulating sound effect and includes a pair of continuously rotating eyeballs. The various action features are initiated incident to a vocal command from the player and are driven by a self-contained power source.

In appearance, the toy takes the form of a mechanical robot 17 which is controlled by a remote unit 19 (see FIGURES 8 and 9) and which includes a main body 21 carried by a tricycle support including two independently movable forwardly located drive wheels 23 and 25 and a rearwardly located caster wheel 27 (see FIGURE 2). The main body 21 can be fabricated in various ways and, in the disclosed construction, two mating plastic sections are utilized. At the top of the main body 21 is a head 29 which includes the before-mentioned rotating eyeballs 31 and 33. Rotatably carried at the shoulders of the robot main body are a pair of arms 35 and 37. In the disclosed embodiment, the projectile discharging features include a rocket firing device 39 located in the head 29 (see FIGURES 2, 10, and 11), and a ball throwing mechanism 41 associated with each of the arms 35 and 37 (see FIGURES 12, 13, and 14).

Secured within the main body 21 is a frame 43 (see FIGURE 2) which includes a main platform 45, together with a pair of transversely spaced upright posts 47 and 49 (see FIGURES 2 and 4) and a cross beam 51 (see FIGURES 2, 4, and 13) connecting the upper ends of the posts 47 and 49.

As seen especially in FIGURE 3, there is mounted to the platform 45 a pair of upright plates 53 and 54 which constitute a sub-frame supporting a small direct current electric motor 55, and a speed reducing gear train 57, as well as various components which can be selectively connected to the gear train 57 to cause the various action operations. In the disclosed construction, the motor 55 is electrically connected to and powered by a series of batteries 59 mounted in a battery pack 61 (see FIGURE 2) which is snap fitted into the back of the main body 21. However, another source of energy could be used as well as an alternating current type motor. In addition, a spring wound motor with a suitable release mechanism could also be employed.

The speed reducing gear train 57, through which the various operating components are powered, is driven, as seen in FIGURE 3, by a pinion 61 on the output shaft of the motor 55 and includes, in part, a series of intermeshed first, second, third, and fourth gear and pinion assemblies 63, 65, 67, and 69 which are respectively carried on cross shafts 71, 73, 75, and 77 journaled in the side plates 53 and 54.

Suitable means are provided for selective connection of the various operating components to the gear train 57. In the disclosed construction, this means takes the form of a bifurcated slide 79 which is guided for linear movement by the lower margins of the side plates 53 and 54 and by suitable lugs (not shown) projecting from the side plates. Movement of the slide 79 is controlled, as will be later described, by the remote unit 19.

The slide 79, as seen best in FIGURE 7, incorporates

a series of cam surfaces 81, 83, and 85 which are arranged to selectively connect either or both of the drive wheels 23 and 25 to the motor 55 to cause movement of the robot either ahead, or to the left, or to the right. Also included on the slide are cams 87 and 89 which are respectively operable to actuate the rocket firing device 39 located in the head 29 of the robot and to cause rotation of the arms 35 and 37 so as to effect throwing of objects from the robot.

Considering the mechanism by which travel of the robot is controlled, each of the drive wheels 23 and 25 is independently connectable to the gear train 59 by separate, but generally identical means or arrangements. Accordingly, only the arrangement for driving the drive wheel 23 will be disclosed, it being understood that the other drive arrangement is constructed and operates in a similar manner. Specifically, as shown in FIGURES 3 and 6, the wheel 23 is rotatably mounted on a shaft 91 extending through the lower forward part of the main body 21 and includes, adjacent the main body, a portion 93 of reduced diameter which takes the form of a gear. Connectable between the gear portion 93 of the wheel and a gear 95 connected exterior of the side plate 54 on a cross shaft 97 extending between the side plates 53 and 54, is a pinion 99 mounted for rotation on a pivot lever 101. The lever 101 is pivoted about the cross shaft 97 and the pinion 99 is rotatably mounted on the lever so as into and out of meshing engagement with the gear portion 93 of the drive wheel 23 incident to pivoting of the lever 101. In turn, the cross shaft 97 also carries a gear 103 in mesh with the fourth gear and pinion assembly 69.

Depending from the lever 101 is an arm 105 having a wedge 107 at its lower end which, as the pinion 99 moves out of meshing engagement with the gear portion 93 of the drive wheel 23 incident to clockwise pivoting of the lever 101, as seen in FIGURE 6, engages within one of the tooth spaces on the gear portion 93 to lock the drive wheel 23 against rotation. As seen in FIGURE 6, the lever 101 is biased in the counterclockwise direction by suitable means which, in the disclosed construction, takes the form of a leaf spring 109 engaging the rearward end of the lever 101 so as to urge the pinion 99 into meshing engagement with the gear portion 93 of the drive wheel 23. However, the lever 101 is generally restrained from such movement by engagement of an ear 111 which projects from the rearward end of the lever 101 for engagement with a ledge 113 (see FIGURE 7) extending along the side of the slide 79.

As can be seen best in FIGURE 7, the before-mentioned camming surfaces 81, 83, and 85 constitute upwardly inclined notches in the ledges 113 which permit swinging of the levers 101 under the influence of the leaf springs 109 so as to serve the dual function of unlocking the drive wheels 23 and 25 for rotation and of engaging the pinions 99 with the drive wheels so as to cause their rotation in the advancing direction. The camming surfaces 81, 83, and 85 are progressively arranged from the forward end of the slide, seen to the right in FIGURE 7, so that, incident to progressive forward positioning of the slide, the left drive wheel 23 is rotated while the right wheel 25 is locked against rotation, thereby pivoting the robot to the right, so that both wheels 23 and 25 are rotated to advance the robot, and finally, so that the right drive wheel 25 is rotated while the left wheel 23 is locked against rotation, thereby pivoting the robot to the left. In this connection, it will be observed, that the rearward portion of the camming surface 81 is located directly across from camming surface 83 so that both drive wheels can be simultaneously connected to the gear train 57.

Continued forward positioning of the slide 79 relative to the "turn left position" operates to cause release of the rocket firing device 39 contained in the head 29 of the robot. More particularly, as seen best in FIGURE 5, the cam 87 on the slide 79 is positionable under one

depending leg 114 of a pivotally mounted, inverted Y lever 115 so as to rotate the Y lever in the counterclockwise direction, as seen in FIGURE 5, thereby effecting release of a rocket 117 (see especially FIGURE 11) in the head of the robot. The Y lever 115 is pivotally carried on the fourth cross shaft 77 and includes, on its stem 119, a pinion 121 which is located so as to be continually in mesh with a gear 123 fixed exterior of the plate 53 on the fourth cross shaft 77, and so as to be movable, incident to pivoting of the Y lever 115, into and out of engagement with a drive gear 125 rotatably mounted on a stud 127 projecting from the plate 53.

The Y lever 115 is normally biased by suitable means so that the pinion 121 is in a neutral or disengaged position relative to the drive gear 125. In the disclosed construction, this biasing means takes the form of a double-ended leaf spring 129 which is suitably mounted, as shown, on the plate 53 so that its opposed ends engage pins 131 and 133 respectively anchored in the previously mentioned depending leg 114 and in the other depending leg 135.

The drive gear 125 operates, when connected to the gear train 57, to reciprocate a throw rod 137 (see FIGURES 2, 5, and 10) so as to perform the dual function of opening a door 139 (see FIGURES 1 and 2) in the head 29 of the robot and of releasing the rocket 117 carried in launching position by the firing device 39. More particularly, the throw rod 137 is pivotally connected at its lower end to a stud 141 on the drive gear 125 and is guided adjacent its upper end by a post or pin 143 (see FIGURE 10) anchored in a block 145 (see FIGURES 2 and 10) supporting the rocket firing device 39. The post 143 is positioned to locate the top of the throw rod 137 so that, incident to upward movement of the throw rod, the undersurface of the door 139 is engaged and swung upwardly to its open position to permit travel of the rocket outwardly of the robot head incident to release of the rocket. In this connection, the door is suitably hinged along its rearward edge to the robot head 29. Preferably, the door 139 is fabricated of transparent material so that the rocket 117 can be seen within the head of the robot.

The rocket firing device 39 is adapted to discharge the rocket 117 and to cause operation of a noise making means 146 (see FIGURE 10), which means, in the disclosed construction, produces a noise effect resembling a siren sound. More particularly, the rocket firing device is supported on the before-mentioned block 145 which is mounted, in part, on the cross beam 51 extending between the upright posts 47 and 49, and, in part, by a tongue 147 which is interfitted in a mating notch or groove in a projection 149 on the inside of the robot head 29. Extending within the block 145, as seen best in FIGURE 10, in an upwardly inclined disposition, is a channel or guideway 151 which receives a plunger 153 for axial movement therein.

The plunger 153 includes a lower portion 155 of non-circular cross section which prevents rotation of the plunger in the block and which also serves to limit upward movement of the plunger outwardly of the block by engagement with a shoulder 157 (see FIGURE 11) within the guideway adjacent the top face of the block. Included on the lower plunger portion 155 is a rack 159 which is engageable with a pinion 161 mounted on a cross arbor 163 journaled in the block. The pinion 161 forms a part of the siren sound noisemaker, still to be described.

At its upper or outer end, the plunger 153 takes the form of a cylindrical rod 165 which is of smaller diameter than one dimension of the lower portion 155 and which passes through a rocket-aligning hub 167 projecting from the top face of the block. At its extreme upper end, there is suitably attached, as by the illustrated screw 169, a stop in the form of a washer 171 which is of larger outside diameter than the rod. The washer 171 functions

to retain on the rod 165 a flanged collar 173 which is otherwise axially slidable upon the rod between the washer 171 and the block 145. Surrounding the rod 165, between the collar 173 and the bottom of a well 175 in the rocket-aligning hub 167, is a helical power spring 177.

Located for pivotal movement across the top face of the block 145 is a latch member 179 which is suitably biased by a spring 181 for movement toward a position locking the rocket 117 against release. The latch member 179 includes an ear 183 which is engaged by a bent portion 185 of the throw rod 137 to cause movement of the latch member 179 away from its rocket engaging position incident to the terminal portion of the upward movement of the throw rod, which movement also completes opening of the door 139 at the head of the robot to permit passage of the released rocket.

The rocket 117 is particularly designed for cooperation with the latch member 179 to retain the rocket in position ready for release, and with the plunger 153-collar 173-power spring 177 arrangement so as to facilitate spring powered launching of the rocket, as well as delayed operation of the siren noisemaker 146. As seen in FIGURE 11, the rocket 117 comprises a hollow elongated, generally cylindrical body having a rounded nose and an open base. The base is proportioned for a sliding fit on the rocket-aligning hub 167 and includes a flange 187 engageable by the latch member 179 to retain the rocket on the hub against the force of the power spring 177. Approximately mid-way of the rocket there is provided a shoulder 189 which forms a bore permitting passage of the rod 165 and washer 171, but which limits travel of the collar 173. Located outwardly of the shoulder 189 within the rocket is a wall or stop 193 which is engaged by the outer tip of the plunger rod 165 incident to loading of the rocket on the plunger 153.

As can be seen from FIGURE 11, when the rocket 117 is loaded on the plunger 153, the collar 173 is first engaged by the shoulder 189 to compress the power spring 177 as the collar 173 slides inwardly along the rod 165. When the spring 177 reaches a partially compressed condition, the outer tip of the rod engages the wall 193, which engagement causes inward travel of the plunger 153 relative to the block 145. At the same time, the power spring 177 is further compressed by continued engagement of the shoulder 189 with the collar 173. Inward movement of the plunger 153 engages the rack 159 with the pinion 161. When the rocket 117 is seated on the aligning hub 167 in position for engagement by the latch member 179 to prevent unwanted discharge of the rocket, the power spring 177, as seen best in FIGURE 11, is essentially fully compressed.

When the throw rod 137 is moved upwardly by the drive gear 125, the latch member 179 is swung from its position of retaining engagement with the flange 187 of the rocket 117. The power spring 177 then acts through the collar 173 against the shoulder 189 to launch the rocket from the plunger. As the power spring 177 expands, the collar 173 travels outwardly of the plunger rod 165 until it contacts the washer 171, after which the power spring 177 also rapidly drives the plunger 153 outwardly of the block 145. This movement of the plunger 153 causes rotation of the pinion 161 and consequent operation of the siren noisemaker 146 at a time subsequent to launching of the rocket 117 from the head of the robot.

The siren noisemaker 146 incorporates, in addition to the pinion 161, a sounding box or chamber 195 including a diaphragm 197 of shim stock, fish paper, or other suitable material. Secured generally centrally of the diaphragm 197 is a vibrator or reed 199 which extends for engagement of its free end with the teeth of the pinion 161. The arbor 163 carrying the pinion 161 preferably also supports a fly wheel (not shown) so that rotation of the pinion will be sustained for a relatively prolonged time interval after disengagement of the rack 159 from the

pinion 161 incident to the terminal portion of the outward plunger travel. Thus, sustained rotation of the pinion 161 causes continued vibratory action of the vibrator 199 with a consequent siren noise effect being produced.

Returning now to the slide 79 and its selective movement relative to the plates 53 and 54, as the slide is moved forwardly of its rocket releasing position, the cam 87 permits return of the Y lever 115 to its central or neutral position in which, as seen in FIGURE 5, the drive gear 125 is disengaged from the pinion 121. Further forward movement of the slide 79 is effective to actuate the ball throwing arms 35 and 37 of the robot by engagement of the cam 89 with the end of the depending leg 135 of the Y lever 115 so as to rock the Y lever clockwise, as seen in FIGURE 5, from its central or neutral position. This movement effects engagement of the pinion 121 with a gear 201 rotatably carried on a stud 203 fixed to the plate 53. In turn, the gear 201 engages an idler gear 205 carried by a second stud 207 fixed to the plate 53. Fixed to the idler gear 205 is a sprocket 209 which is connected through an endless chain 211 to a second sprocket 213 (see FIGURE 4) fixed on a cross shaft 215 which extends through and is journaled by the upright posts 47 and 49. Engagement of the pinion 121 with the gear 201 causes the cross shaft 215 to rotate in the clockwise direction, as seen in FIGURE 4. Carried for free rotation at the ends of the cross shaft 215, exteriorly of the main body 21, are the arms 35 and 37. The arms are secured on the cross shaft 215 by suitable means, such as a threaded nut which may take a decorative form such as indicated at 216 in FIGURES 12 and 13.

Each of the arms 35 and 37 of the robot is generally identical, both in construction and operation, except for being left and right handed. Accordingly, only the arm 35 will be described. The arm 35 is generally a hollow element or body including a main part 217 providing, at least in part, a magazine for containing a plurality of balls 219, which balls are preferably of light weight, such as ping pong balls, only smaller in size. The top of the main part 217 is closed by a cover 221 which, in the disclosed construction, is suggestive of an epaulet and is hinged, as indicated at 220, to the main part 217. Suitable means are provided for retaining the cover closed, such as a spring or the illustrated clip 222. At the lower end of the arm 35, there is provided a cup or receptacle 223 which is rearwardly open when the arm is downwardly hanging from the cross shaft 215. Connecting the cup 223 and the main part 217 is an intermediate part 225 which carries at least a part of a device 227 for feeding balls 219 one at a time to the cup 223.

The balls 219 are thrown from the cups 223 by intermittent rapid rotation of the arms, one ball being thrown for each complete swing of each arm. This intermittent and rapid rotative movement of each of the arms 35 and 37 is provided by separate and generally identical drive mechanisms 229 (see FIGURE 13), both of which are driven off the cross shaft 215 and include a coil spring 231 and a cam controlled latch 233 operable to releasably anchor one end of the coil spring 231 while the other end is rotated so as to "cock" or to store energy in the coil spring. As the drive mechanisms are generally identical except for being left and right handed and except for being arranged so that the arms 35 and 37 operate alternately, only the drive mechanism associated with the arm 35 will be described.

More particularly, the cross shaft 215 has fixed thereto, outwardly of each of the upright posts 47 and 49, a cam 235 which includes a camming surface 237 and an outwardly projecting central hub with a radial slot 239 therein. The coil spring 231 is located around the hub with its inner end fixed in the slot 239. The outer end of the coil spring 231 includes a reentrant portion defining a hook 241 for engagement with the edge 243 of a stepped ear or tab 245 extending toward the main body 21 from the adjacent side of the arm 35. As will be seen, the

ear 245 co-acts both with the latch 233 and with the coil spring 231 to cause ball throwing activity. The coil spring 231 is proportioned and the slot 239 in the hub is located such that immediately after ball throwing action of the arm 35, when the coil spring 231 is not under tension, the hook 241 is somewhat angularly displaced, rearwardly with respect to the direction of angular rotation of the cross shaft 215, from the edge 243 on the ear 245 of the arm 35. Encasing the coil spring 231 is a shell 247 which prevents hindering of the rotative movement of the arm 35 due to interfering engagement of the side edge of the coil spring with the cam 235. As shown, a suitable crescent shaped opening 249 is provided in the shell 247 to permit passage therethrough of the ear 245 for engagement of the edge 263 with the stop 261 of the latch 233.

Forming a part of the cam operated latch 233 is an L shaped member 251 which includes a horizontally disposed leg 253 which is pivotally connected at its outer end to the cross beam 51 so that the shorter or vertical leg 255 lies flush against the outside of the upright post 47. As shown, the short leg 255 also includes a pair of wings 257 which engage the front and rear faces of the upright post 47 to guide pivotal movement of the L shaped member 251. Also provided are suitable biasing means urging the L shaped member 251 into flush relation to the cross beam 51 and upright post 47. In the disclosed construction, this means takes the form of a leaf spring 259 suitably attached, as by a rivet (not shown), to the inside of the main body 21.

Projecting from the vertical leg 255 of the L shaped member 251 is a stop or tab 261 which is engaged at its lower edge by the camming surface 237 and is engageable along its forward face by edge 263 of the stepped ear 245. Engagement of the stop 261 by the ear 245 locates the arm 35 in the downwardly hanging position and prevents rotation of the arm by the coil spring 231 except when the stop 261 is elevated out of engagement with the ear 245 by action of the cam 235.

More specifically, in operation, after the arm 35 has completed its ball throwing movement, it hangs in a vertical position with the ear 245 engaged with the stop 261 on the L shaped member 251, which member is held in flush engagement with the cross beam 51 and upright post 47 by the leaf spring 259. At the same time, the hook 241 of the coil spring 231 is angularly displaced from the ear 245, but as the cross shaft 215 continues its rotation, the hook moves into engagement with the ear to anchor the outer end of the coil spring, and to thereby cause "cocking" of the coil spring incident to continued rotation of the cross shaft. This rotation of the cross shaft 215 also serves to subsequently pivotally elevate the stop 261 so as to disengage it from the ear 245 and permit rapid swinging of the arm 35, under the influence of the coil spring 231, counterclockwise, as seen in FIGURES 12 and 13. This fast rapid motion results in throwing of one of the balls 219 from the cup 223 at the end of the arm 35 as the arm passes through the top of its path.

Passage of the balls 219, one for each rotation of each of the arms 35 and 37, from the magazine in the main part 217 of the arm into the cup 223 is facilitated by the before-mentioned ball feeding device 227, seen best in FIGURES 12 and 14. This device comprises a bell-crank lever 265 which is pivotally mounted on the intermediate part 225 of the arm 35 and which is biased by suitable means, such as the illustrated spring 267, for rotation in the direction of rotation of the arm. In this regard, there is provided on the outside of the cup 223 a lug 269 which prevents over-travel of the lever 265 in the counterclockwise direction, as shown in FIGURE 12. The bell-crank lever 265 is shiftable clockwise, as seen in FIGURE 12, against the action of the biasing spring 267 from a position preventing passage of the balls from the magazine and through the bottom of the intermediate part 225 into

the cup, to a position permitting passage from the intermediate part 225 of the lowermost ball therein to the cup 223. More specifically, the upper arm 271 of the lever 265 has at its forward end a transversely projecting, outwardly convex plate or section 273 which has generally a radius of curvature corresponding to that of the balls 219, and which serves generally to prevent passage of balls 219 from the magazine to the cup. However, when the lever is rotated clockwise, as seen in FIGURE 12, from its position closing the bottom of the intermediate part 225, the lowermost ball is permitted to fall into the cup 223 while, at the same time, the adjacent upper ball is restrained from movement into the cup by engagement of the top edge of the transverse curved section 273.

Movement of the bell-crank lever 265 against the action of the biasing spring 267 from its position closing the opening at the bottom of the intermediate part 225 is provided, as the arm is rotated upwardly and backwardly from its vertically hanging position, by engagement of a lug 275 extending from the lower end of the lever arm 277 with a projection 279 on the adjacent side of the main body 21.

In addition to the previously described activities of the robot, the eyeballs 31 and 33 of the disclosed construction are continuously rotated whenever the motor is energized. More specifically, the eyeballs, as seen best in FIGURE 4, are generally of identical construction, each being of rounded, generally conical formation, including a rearward serrated cylindrical portion 281 in meshing engagement with the corresponding portion of the other eyeball. The eyeballs are mounted at the forward end of a pair of shafts 283, each shaft being journaled in a bracket 285 fixed to the cross beam 51. Suitable means are provided, such as the enlarged shaft portions 287, for preventing axial displacement of the shafts 283 relative to the bracket 285.

The eyeballs 31 and 33 are driven for rotation through a sheave or pulley 289 fixed to one of the shafts 283, which pulley is connected by a belt 291, such as a rubber band, to a second sheave or pulley 293 fixed, as seen in FIGURES 3 and 6, exterior of the plate 54 on the fourth cross shaft 77 of the gear train 57. Thus, when the motor is in operation, one eyeball is rotated in the clockwise direction while the other eyeball is rotated in the counterclockwise direction. The eyeballs are further provided with decorative, eccentric circular rings of different color than the remainder of the eyeballs. This provision, coupled with rotation of the eyeballs, provides a very unusual and fascinating visual effect.

As previously mentioned, the robot also includes suitable means 295 (see FIGURES 2 and 3) for producing a vitality simulating noise effect. The noise effect produced by the disclosed construction is suggestive of an imaginary heartbeat, is produced at predetermined time intervals, and comprises two closely spaced high-pitched sounds.

More specifically, the sound producing means 295 includes, as seen best in FIGURES 2 and 3, two generally identical sound makers 297 which are located in a recess in the platform 45. Each of the sound makers 297 includes a resilient bulb or bellows 299 which is collapsible and a reed 301 which produces a squeaking sound incident to inflow of air through the reed into the bulb 299.

Collapse of each of the bulbs in closely timed relation to provide the desired noise effect is provided by a pair of paddle levers 303 which are pivotally carried on a bracket 305 mounted on the platform 45. The forward end of each of the paddle levers 303 is engageable with one of a pair of tabs 307 struck from opposite sides of a disk 309 mounted exterior of the side plate 53 on the third cross shaft 75 in the gear train 57. Thus, for each rotation of the disk 309, each of the sound makers 297 is collapsed to subsequently produce a squeaking sound. The time interval between the sounding operation of each of the sound makers 297 in one cycle is considerably smaller

than one half the time interval between repeated sounding operation of the same sound maker. In this manner, the closely occurring operation of the sound makers 297 can be considered one composite sound which is repeated at intervals as long as the motor is running.

As previously indicated, travel of the robot 17, launching of the rocket 117, and throwing of the balls 219, is controlled by the remote unit 19 which is mechanically connected to the robot, as seen in FIGURES 2 and 8, through a flexible cable 311 including a tube 313 of suitable plastic material. More particularly, in the disclosed construction, the remote unit 19 is intended to simulate a microphone and includes a knob 315 which is selectively movable so as to control the travel of the robot, release of the rocket 117, and ball throwing operation of the arms 35 and 37. Also included in the remote unit is a motor control switch 317 which is biased open by a mechanical "lock out" and which is closable, after release of the "lock out," by sound command. The mechanical "lock out" incorporates a button 319 which is biased so as to automatically return the switch to the open position.

Still more particularly, the remote unit 19 includes a casing 321 which generally contains the operating components and a cover plate 323 for the casing. Movement of the slide 79 in the robot to control robot activity is governed by the movement of a flexible steel wire or shaft 325 which is incased in a plastic covering 327 and which extends within the flexible tube 313. At one end, the wire 325 is connected to the slide 79 in the robot and at its other end is connected to a movable block 329 carried in a guideway 331 in the casing 321. Movement of the block 329 in the casing therefor results in corresponding movement of the slide 79 in the robot.

The guideway 321 includes a rack 333, while the block 329 carries a rotatably mounted pinion 335 engaged with the rack 333. Extending from the pinion 335 on the block through an elongated slot 337 in the cover plate 323 is the knob 315 by which the pinion can be rotated to linearly move the block. Connected to the block 329 and also extending through the slot 337 is a pointer 339 which, by comparison to suitable markings on the cover plate 323, indicates the position of the block and the corresponding robot activity.

As pointed out before, electrical control of the motor 55 is provided by an audio switch 317 having a mechanical "lock out" feature. More specifically, one of the terminals of the motor 55 is connected by a lead 341 to a contact post 343 in the casing, which lead 341 extends within the flexible tube 313 of the cable 311. In addition, one of the terminals of the battery pack 61 is connected by a second lead 345 to a second contact post 347 located in the casing in adjacent relation to the first contact post 343. The lead 345 extends within the flexible tube 313 of the cable 311.

The contact posts 343 and 347 are electrically connectable by a bridging contact or bus bar 349 which is fixed to a diaphragm 351 pivotally mounted in the casing 321. The position of the diaphragm is controlled, in part, by a light, over-the-center tension spring 353 which, as shown, connects a point near the center of the diaphragm 351 with a point in the casing spaced on the other side from the pivotal axis of the diaphragm. Thus, the over-the-center spring 353 operates either to bias the diaphragm 351 toward either of a first, open position in which the bus bar 349 is spaced from the contact posts 343 and 347 and a second, closed position in which the bus bar 349 engages both posts 343 and 347 to electrically energize the motor.

The strength of the over-the-center spring 353 which biases the diaphragm 351 is such that air pressure accompanying adjacent, moderately loud vocal activity will throw the diaphragm 351 from its open to its closed position. In this regard, the portion of the cover plate 323 overlying the diaphragm 351 is slotted or otherwise

formed to provide for the passage of pressure waves accompanying a vocal command.

The mechanical "lock out" feature of the motor control switch 317 includes the button 319 which extends inwardly through one side of the casing into a position under the diaphragm 351. The button 319 includes an extending part 355 which passes through an opening in a wall 357 in the casing so as, in cooperation with the opening in the side of the casing, to guide in and out movement of the button. Carried on the extending part 355 between the wall 357 and the main part of the button 319 is a spring 359 which biases the button outwardly of the casing. In this regard, the button 319 includes a lug 361 which engages the casing to prevent displacement of the button out of the casing.

Biasing of the diaphragm 351 by the button 319 to its open position is provided by an inclined cam surface 363 on the button, which surface is operable through an opening 365 in the diaphragm and against one edge of the opening 365. The inclination of the cam surface 363 is such that, incident to inward movement of the button 319, the cam surface rides out of engagement with the before-mentioned edge to permit movement of the diaphragm to its closed position. However, whenever the button is released, the spring 359 urges the button 319 outwardly of the casing, whereby the cam surface 363 engages the diaphragm 351 so as to return the diaphragm to its open position. In this regard, the strength of the button biasing spring 359 is greater than that of the over-the-center spring 353 and, thus, when the button is not depressed into the casing, the motor 55 is automatically disconnected from the batteries 59.

In order to close the circuit to the motor 55, the button 319 must first be pressed inwardly to disengage the cam surface 363 from the diaphragm 351 so as to permit subsequent movement of the diaphragm from its normally open to its closed position, followed by a vocal command sufficiently loud to overcome the over-the-center spring 353 and thereby carry the diaphragm to its closed position. The circuit to the motor 55 is automatically opened whenever the button 319 is released from its inwardly pressed position. This arrangement provides the important advantage of assuring that the motor circuit 55 will always be open when the remote unit is not in use.

In summary, the disclosed robot 17 constitutes a self-powered movable mechanism which is capable of various activities and which is controllable from the remote unit 19. This remote unit includes the switch 317 which is operable to energize the motor 55 incident to a sound command and which incorporates an automatic "lock out" feature for de-energizing the motor. Also included in the remote unit is a selector by means of which various of the operating mechanisms in the robot can be connected and disconnected to the motor to selectively control the activity of the robot. These features include selective travel of the robot along a supporting surface, firing of the rocket 117 from the head 29 of the robot, and successive throwing of a plurality of the balls 219 carried in the arms 35 and 37 of the robot. Provision is also made for continuous powering by the motor of the sound producing means 295 and of the pair of constantly rotating eyeballs 31 and 33.

Various of the features of the invention are set forth in the following claims.

What is claimed is:

1. An animated toy comprising a housing, at least two spaced wheels mounted on said housing for rotation so as to propel said housing for movement along a supporting surface, motor means on said housing, means rotatably supported on said housing and operable to cause an object to be thrown from the toy as said means is rotated relative to said housing, means on said housing for releasably holding a projectile for discharge, means for releasing said projectile-holding means and for causing

discharge of the projectile, selective connecting means on said housing for selectively connecting said motor to said wheels so as to drive said housing or to said means for releasing said projectile-holding means so as to cause discharge of the projectile, and for selectively connecting said motor to said rotatable throwing means so as to throw objects from said toy, and means remote from said housing and mechanically connected to said selective connecting means to provide for controlled operation of the latter to effect movement of the toy along its supporting surface, discharge of a projectile from the toy, or cause the toy to throw an object by operation of said rotatable means.

2. An animated toy, comprising a housing at least two spaced wheels mounted on said housing for independent rotation so as to propel said housing for movement along a supporting surface, motor means on said housing, means on said housing for releasably holding a projectile, means for releasing said projectile-holding means, means on said housing for selectively connecting said motor to each of said wheels so as to selectively drive said housing ahead, to the left and to the right, and to said means for releasing said projectile-holding means so as to cause discharge of the projectile, and means remote from said housing for selectively controlling said selective connecting means, and means mechanically connecting said controlling means to said selective connecting means whereby operation of said toy can be controlled.

3. An animated toy comprising a housing having an opening therein with a door swingable relative to a position closing said opening, at least two spaced wheels mounted on said housing for independent rotation so as to propel said housing for movement along a supporting surface, motor means on said housing, means on said housing for releasably holding a projectile within said housing in position for discharge through said opening, means for moving said door from said closed position to an open position to facilitate discharge from said housing of said projectile and for releasing said projectile-holding means, means on said housing for selectively connecting said motor to each of said wheels so as to selectively drive said housing ahead, to the left and to the right, and for connecting said motor to said means for moving said door and for releasing said projectile-holding means so as to cause discharge of the projectile from said housing, means remote from said housing for selectively controlling said selective connecting means, and means mechanically connecting said controlling means to said selective connecting means whereby operation of said toy can be controlled.

4. An animated toy comprising a housing, at least two spaced wheels mounted on said housing for rotation so as to propel said housing for movement along a supporting surface, motor means on said housing, means on said housing for releasably holding a projectile for discharge and for producing a sound effect subsequent to release of the projectile, means on said housing for operating said projectile-holding and sound-producing means so as to release the projectile and produce the sound effect, means on said housing for selectively connecting said motor to said wheels so as to drive said housing and to said means for operating said projectile-holding and sound-producing means so as to cause discharge of the projectile and production of the sound effect, means remote from said housing for selectively controlling said selective connecting means, and means mechanically connecting said controlling means to said selective connecting means whereby operation of said toy can be controlled.

5. An animated toy comprising a housing, at least two spaced wheels mounted on said housing for independent rotation so as to propel said housing for movement along a supporting surface, motor means on said housing, means on said housing operable incident to rotation for throwing objects, means on said housing for selectively connecting said motor to each of said wheels so as to selectively drive said housing ahead, to the left and to the right, and to said throwing means so as to throw objects

from said toy, means remote from said housing for selectively controlling said selective connecting means, and means mechanically connecting said controlling means to said selective connecting means whereby operation of said toy can be controlled.

6. An animated toy comprising a housing, at least two spaced wheels mounted on said housing for independent rotation so as to propel said housing for movement along a supporting surface, motor means on said housing, means on said housing operable incident to rotation for throwing objects, means on said housing for releasably holding a projectile for discharge, means for releasing said projectile-holding means, means on said housing for selectively connecting said motor to each of said wheels so as to selectively drive said housing ahead, to the left and to the right, to said means for releasing said projectile-holding means so as to cause discharge of the projectile, and to said throwing means so as to throw objects from said toy, means remote from said housing for selectively controlling said selective connecting means, and means mechanically connecting said controlling means to said selective connecting means whereby operation of said toy can be controlled.

7. The combination in a toy of a frame, first and second wheels supported by said frame for independent rotation so as to propel said frame along a supporting surface, a motor, first means mounted on said frame for movement to and from between a first position drivingly connecting said first wheel to said motor and a second position locking said first wheel against rotation, second means supported on said frame for movement to and from between a first position drivingly connecting said second wheel to said motor and a second position locking said second wheel against rotation, and means for selectively positioning said first and second means in said first positions so as to selectively drive said toy ahead, to the right, and to the left.

8. The combination in a toy of a frame, first and second wheels supported by said frame for independent rotation so as to propel said frame along a supporting surface, a motor, first means mounted on said frame for movement to and from between a first position drivingly connecting said first wheel to said motor and a second position locking said first wheel against rotation, second means supported on said frame for movement to and from between a first position drivingly connecting said second wheel to said motor and a second position locking said second wheel against rotation, means biasing said first and second means toward said first positions, and selectively positionable means for selectively retaining said first and second means in said second positions against the action of said biasing means for selectively enabling movement, under the action of said biasing means, of said first and second means to said first positions, so as to cause the toy to stop, to advance, to turn left, and to turn right.

9. The combination in a toy of a frame, first and second wheels supported by said frame for independent rotation so as to propel said frame along a supporting surface, a motor, a first pivotal means mounted on said frame for movement to and from between a first position drivingly connecting said first wheel to said motor and a second position locking said first wheel against rotation, a second pivotal means supported on said frame for movement to and from between a first position drivingly connecting said second wheel to said motor and a second position locking said second wheel against rotation, means biasing said first and second pivotal means toward said first positions, selectively positionable means for retaining said first and second pivotal means in said second positions against the action of said biasing means for selectively enabling movement, under the action of said biasing means, of said first and second pivotal means to said first positions, control means remote from said frame for selectively locating said selectively positionable

means so as to selectively control movement of said frame, including movement of said frame ahead, to the left, and to the right, and means mechanically connecting said selectively positionable means and said remote control means.

10. An animated toy comprising a housing; a motor mounted on said housing; first and second wheels supported by said housing for independent rotation so as to propel said housing along a supporting surface; a first means mounted on said housing for movement to and from between a first position drivingly connecting said first wheel to said motor and a second position locking said first wheel against rotation; a second means supported on said housing for movement to and from between a first position drivingly connecting said second wheel to said motor and a second position locking said second wheel against rotation; means biasing said first and second means toward said first positions; means on said housing for throwing objects by rotative force; said means including a shaft connectable to said motor, journaled in said housing, and extending outwardly of said housing; an arm rotatably carried on said shaft; said arm including a receptacle adapted for receiving an object to be thrown, being spaced from said shaft, and being open in the direction of rotation of said shaft; and means for drivingly connecting said shaft to said arm to cause the latter to be rotated so as to throw the object from said receptacle; said drive-connecting means including a spring having one end fixed to said shaft and having its other end engageable with said arm to cause rotation of said arm in the direction of rotation of said shaft; latch means carried by said housing for releasably engaging said arm to prevent rotation thereof, whereby said spring is tensioned incident to continued rotation of said shaft; and rotary means carried by said shaft for releasing the engagement of said latch means with said arm after tensioning of said spring so as to cause rapid rotation of said body for throwing the object from said receptacle; means on said housing for holding and firing a rocket and for producing a sound effect subsequent to discharge of said rocket; said last mentioned means comprising support means on said housing; an elongated plunger on said support means; said plunger extending partially in outwardly projecting relation to said support means and being movable inwardly and outwardly of said support means; a member movable on said plunger axially thereof between the outer end thereof and said support means; a compression spring on said plunger contained between said movable member and said support means; said spring normally maintaining said movable member adjacent the outer end of said plunger; a rocket mountable on said plunger in abutting relation to said movable member and against the action of said compression spring; means releasably holding said rocket on said plunger against the action of said compression spring; a sounding chamber including a diaphragm mounted on said support means; and means for vibrating said diaphragm incident to outward movement of said plunger occurring subsequent to discharge of said rocket; selectively movable means on said housing for connecting said motor to said first and second wheels by movement to and from between positions retaining said first and second pivotal means in said second positions against the action of said biasing means and positions enabling selective movement, under the action of said biasing means, of said first and second pivotal means to said first positions, so as to control travel of the toy, for connecting said motor to said means for releasing said rocket-holding and sound producing means so as to cause discharge of said rocket and the production of a sound effect and for connecting said motor to said shaft so as to cause object throwing movement of said arm; means remote from said housing for selectively controlling said selectively movable means comprising a casing; a first flexible lead extending from said casing to an electrical power source;

a second flexible lead extending from said casing to said motor so that connection of said leads electrically energizes said motor; movable means for electrically connecting said leads including an element supported by said casing for movement incident to a vocal command; electrical contact means carried by said movable element for travel therewith incident to the vocal command, to a position electrically connecting said leads so as to energize said motor; means normally biasing said movable element away from said position electrically connecting said leads; manual means for deactivating said biasing means; means mechanically shiftable on said casing between various positions; and flexible means mechanically connecting said shiftable means with said selectively movable means so as to obtain related movement of said selectively movable means, thereby controlling the activity of the toy.

11. An animated toy comprising a housing, at least two spaced wheels mounted on said housing for rotation so as to propel said housing for movement along a supporting surface, motor means on said housing, means on said housing operable incident to rotation for throwing objects, a support means on said housing, an elongated plunger on said support means, said plunger extending partially in outwardly projecting relation to said support means and being movable inwardly and outwardly of said support means, said plunger having a stop thereon spaced from said support means, a projectile receivable on said plunger, a member movable on said plunger between said stop and said support means, a compression spring on said plunger contained between said movable member and said support means, said spring normally maintaining said movable member adjacent said stop, sound producing means on said support, said sound producing means being mechanically connectable to said plunger and being operable incident to movement of said plunger outwardly of said support means, means on said housing for releasably holding said projectile on said plunger, means for releasing said projectile-holding means, whereby when said projectile is received on said plunger for subsequent release, said plunger is moved inwardly of said support means and said movable member is engageable by said projectile for movement inwardly of said stop so as to confine said spring, whereafter when said projectile is released, said movable member moves outwardly along the plunger to adjacent said stop so as to fire said projectile, and then causes outward movement of the plunger to operate said sound producing means, means on said housing for selectively connecting said motor to said wheels so as to drive said housing, to said means for releasing said projectile-holding means so as to cause discharge of the projectile, and to said throwing means so as to throw objects from said toy, means remote from said housing for selectively controlling said selective connecting means, and means mechanically connecting said controlling means to said selective connecting means whereby operation of said toy can be controlled.

12. An animated toy comprising a housing, at least two spaced wheels mounted on said housing for rotation so as to propel said housing for movement along a supporting surface, motor means on said housing, a body carried on said housing for rotation, a receptacle on said body adapted for receiving an object to be thrown, said receptacle being spaced from the axis of rotation of said body and being open in the direction of rotation of said body, a magazine in said body for containing a plurality of the objects, said magazine having an aperture communicating with said receptacle for passage of the objects from said magazine to said receptacle, means for controlling passage of the objects from said magazine to said receptacle incident to rotation of said body, said passage controlling means including a trip on said housing and a shiftable member on said body located adjacent said aperture, said shiftable member being engage-

able by said trip incident to rotation of said body, and operable incident to engagement by said trip, to move relative to said aperture so as to permit the passage of a single object into said receptacle, means on said housing for releasably holding a projectile for discharge, means for releasing said projectile-holding means, means on said housing for selectively connecting said motor to said wheels so as to drive said housing, to said means for releasing said projectile-holding means so as to cause discharge of the projectile, and to said rotatable body so as to throw objects from said toy, means remote from said housing for selectively controlling said selective connecting means, and means mechanically connecting said controlling means to said selective connecting means whereby operation of said toy can be controlled.

13. An animated toy comprising a housing, at least two spaced wheels mounted on said housing for rotation so as to propel said housing for movement along a supporting surface, electric motor means on said housing, means on said housing operable incident to rotation for throwing objects, means on said housing for releasably holding a projectile for discharge, means for releasing said projectile-holding means, means on said housing for selectively connecting said motor to said wheels so as to drive said housing, to said means for releasing said projectile-holding means so as to cause discharge of the projectile, and to said throwing means so as to throw objects from said toy, means remote from said housing for selectively controlling said selective connecting means, means mechanically connecting said controlling means to said selective connecting means and, means for energizing and de-energizing of said electrical motor, said energizing and de-energizing means comprising a first lead connected to a power source, a second lead connected to said electrical motor so that electrical connection of said leads electrically energizes said motor, and movable means for electrically connecting said leads including a member supported by said energizing and de-energizing means for movement incident to a vocal command, electrical contact means carried by said movable member for travel therewith, incident to the vocal command, to a position electrically connecting said leads, and means normally biasing said movable member away from said position electrically connecting said leads, said biasing means being manually de-activatable, whereby operation of said toy can be controlled.

14. An animated toy comprising a housing, at least two spaced wheels mounted on said housing for rotation so as to propel said housing for movement along a supporting surface, motor means on said housing, a pair of generally identical noisemakers in said housing, means connected with said motor means for alternately and repeatedly actuating said noisemakers for sounding operation in such relation that the time interval between repeated sounding operations of one of said noisemakers is substantially greater than twice the smaller time interval between alternate sounding operations of said pair of noisemakers, means on said housing operable incident to rotation for throwing objects, means on said housing for releasably holding a projectile for discharge, means for releasing said projectile-holding means, means on said housing for selectively connecting said motor to said wheels so as to drive said housing, to said means for releasing said projectile-holding means so as to cause discharge of the projectile, and to said throwing means so

as to throw objects from said toy, means remote from said housing for selectively controlling said selective connecting means, and means mechanically connecting said controlling means to said selective connecting means whereby operation of said toy can be controlled.

15. A toy comprising a housing, at least two spaced-apart wheels mounted on said housing in supporting relation thereto so as to afford movement of the housing along a supporting surface, means on said housing for releasably holding a projectile and for releasing said projectile for aerial flight, rotatable means on said housing operable incident to rotation thereof for throwing an object carried by said rotatable means, motor means supported on said housing, and means on said housing for selectively connecting said motor to said wheels, to said projectile holding and releasing means, and to said rotatable means, so as to propel the toy, cause discharge of the projectile, and effect throwing of an object by said rotatable means, respectively.

16. A toy comprising a housing, at least two spaced-apart wheels mounted on said housing in supporting relation thereto so as to afford movement of the housing along a supporting surface, means rotatably mounted on said housing and operable incident to rotation thereof for throwing an object carried by said means, motor means supported on said housing, and means on said housing for selectively connecting said motor to said wheels and to said rotatable means so as to propel the toy and effect throwing of an object by the rotatable means as desired.

17. A toy comprising a housing, at least two spaced-apart wheels mounted on said housing in supporting relation thereto so as to afford movement of the housing along a supporting surface, rotatable means on said housing operable incident to rotation thereof for throwing an object carried by said means, said rotatable means comprising a receptacle portion spaced from the axis of rotation of said rotatable means and having an opening facing in the direction of rotation of said means, a magazine adapted to contain a plurality of the objects and having an aperture communicating with said receptacle, and comprising means controlling passage of the objects from said magazine to said receptacle and operable upon rotation of said rotatable means to permit passage of a single object into said receptacle, motor means supported on said housing, and means on said housing for connecting said motor to said wheels and to said rotatable means, so as to propel the toy and effect throwing of an object by said rotatable means as the latter is rotated relative to said housing.

References Cited in the file of this patent

UNITED STATES PATENTS

	1,880,138	Hubl	Sept. 27, 1932
	1,900,353	Marchetti	Mar. 7, 1933
	2,133,038	Muller et al.	Oct. 11, 1938
	2,640,295	Auler et al.	June 2, 1953
	2,775,846	Gazda	Jan. 1, 1957
	2,777,252	Tancredi et al.	Jan. 15, 1957
	2,778,158	Ernst	Jan. 22, 1957
	2,781,753	Formis	Feb. 19, 1957
	2,815,743	Brunderman	Dec. 10, 1957
	2,877,757	Gioragnoli	Mar. 17, 1959
	2,881,559	Glass	Apr. 14, 1959
	2,928,208	Wintriss	Mar. 15, 1960
	2,943,619	Dunbar	July 5, 1960